



CX Premium Salt & Mineral Chlorinator

Chlorinator



Keeping your pool healthy.

New Features

- ✓ Pool Blanket & Winter Mode
- ✓ Heat Junction / Chlorinator Override Function
- ✓ Salt or mineral compatible
- ✓ Variable speed pump compatible
- ✓ Strong reliable construction
- ✓ Easy to use controls
- ✓ Efficient chlorine production
- ✓ Ultra long life self-cleaning cell
- ✓ Fully automated

oasisaquatics.com.au

Part of the  sunlover group

Made from premium grade materials, the Oasis Salt & Mineral Chlorinator provides fast setup and installation.

Features

These units are fully automated, efficiently controlling chlorine production to keep your pool healthy. Our sophisticated units feature self cleaning, backwash, super chlorinate and winter mode functions.

- > Fast setup with new or existing pool systems
- > Cell can be installed horizontally or vertically
- > Variable speed pump compatible
- > Low Salt operations 3000-3500ppm (0.3% - 0.35%) with built in self-regulator for high salt
- > Bright backlit display
- > Smart self cleaning cell electrodes
- > Premium titanium quick connect cell
- > Backwash, super chlorinate and winter mode functions
- > Single or dual timer cycles
- > Salt / TDS test and water flow protection
- > Automatic battery backup timer
- > Suitable for any pool type (concrete, fibreglass, vinyl and tiled)
- > Pool Blanket & Winter Mode
- > Heat Junction / Chlorinator Override Function

Heat Junction / Chlorinator Override Function

is used to avoid over chlorinating the swimming pool, which can often occur when a longer heat up time is required. This allows for a true one pump system to be used with the heater plumbed in line without over chlorinating the pool thus saving time and money.

Pool Blanket & Winter Mode

ensures the chlorinator is dialed down when the blanket is on, ensuring your pool is never over chlorinated.

Specifications

Model	Description	Output	Pool Volume (litres) Cool Climate	Pool Volume (litres) Warm Climate	Max Pump Size	Max Current including Pump
CX15	CX15 Salt & Mineral Chlorinator	15g /hr	50,000	35,000	8 amps	10 amps
CX25	CX25 Salt & Mineral Chlorinator	25g /hr	85,000	55,000	8 amps	10 amps
CX35	CX35 Salt & Mineral Chlorinator	35g /hr	120,000	80,000	8 amps	10 amps
CX45	CX45 Salt & Mineral Chlorinator	45g /hr	160,000	105,000	8 amps	10 amps
CX55	CX55 Salt & Mineral Chlorinator	55g /hr	200,000	130,000	8 amps	10 amps

Dimensions

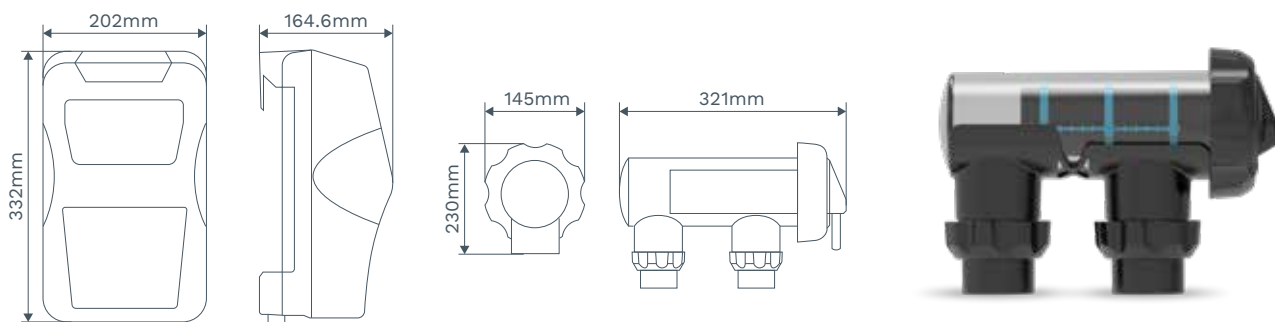

For more details visit
oasisaquatics.com.au

Head Office
6-8 Austral Place
Hallam VIC 3803
T: 03 9887 2131

New South Wales
Unit 2, 10 Boden Road
Seven Hills NSW 2147
T: 02 9838 0000

Queensland
11 Andy Court,
Upper Coomera QLD 4209
T: 07 5679 6821

